

AUTO ELEVADOR ARTICULADO 4X4 OFF ROAD



G E40

ESPECIFICACIONES TECNICAS

Motor - marca / modelo	XINCHAI
Motor - potencia	32 kw / 42 hp
Motor - torque máximo	193Nm
Motor - cilindrada	3 l
Peso	4000 kg
Capacidad de carga (máxima)	2500 kg
Torre doble con desplazamiento	
Altura máxima de carga.	4000 mm
Dispositivo de trabajo	Joystick mecánico
Sistema de frenos	Tambor
Caja - tipo	Powershift
Rodado	12/16.5
Ancho total (J)	1680 mm

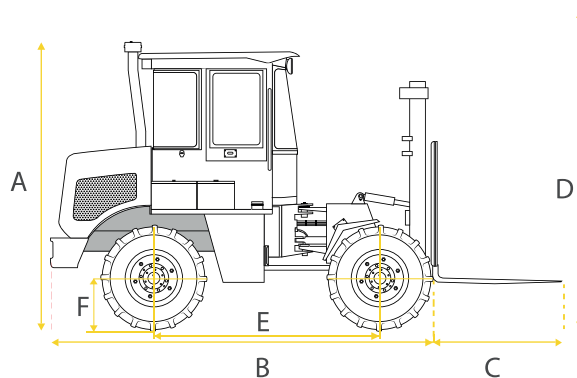

A.....	2750mm
B.....	4080mm
C.....	1120 mm
D.....	4000 mm
E.....	2040 mm
F.....	230 mm



MOTOR XINCHAI
42 hp DIESEL



Capacidad de carga
2500 kg



4 Cambios
2 de avance y
2 de retroceso



Altura máxima de
carga
4000 mm



Peso operativo
4000 kg



Transmisión
Powershift 4WD